



## Patient Guide

Caution: US Federal law restricts this device to sale on or by the order of a physician.

## Contents

1. WELCOME .....	6
2. THE ASPIREASSIST SYSTEM .....	6
2.1 A-Tube™ and Skin-Port™ .....	6
2.2 Companion™ and Accessories .....	7
2.3 Emergency Clamp .....	8
3. WHO IS A CANDIDATE FOR THE ASPIREASSIST? .....	8
4. WHO IS NOT A CANDIDATE FOR THE ASPIREASSIST? .....	8
5. SAFETY INFORMATION.....	9
5.1 Warnings .....	9
5.2 Cautions .....	12
6. RISKS AND BENEFITS .....	13
6.1 Risks Associated with the AspireAssist .....	13
6.2 Benefits of the AspireAssist .....	17
6.3 Aspire Pathway Post Approval Study Summary.....	18
7. IS THE ASPIREASSIST RIGHT FOR ME? .....	21
8. WHAT TO EXPECT BEFORE AND AFTER THE PROCEDURE.....	21
8.1 First Meeting with your Doctor.....	21
8.2 Your Procedure Day .....	22
8.3 Recovering from the Procedure.....	22
8.4 Skin-Port Placement.....	23
9. USING THE ASPIREASSIST .....	24
9.1 AspireAssist Set-Up .....	24
9.2 Attaching Your Device to the Skin-Port .....	25
9.3 Aspirating Your Stomach Contents .....	26
10. DISASSEMBLING AND CLEANING YOUR DEVICE .....	27
10.1 Rinsing After Each Use .....	27
10.2 Daily Cleaning.....	27
10.3 Occasional Cleaning .....	28
10.4 Skin-Port and Site Cleaning Instructions.....	28
10.5 A-Tube Cleaning Instructions .....	28
11. LEARNING HOW TO ASPIRATE SUCCESSFULLY .....	29

11.1	Introducing Foods Little by Little .....	29
11.2	Four Keys to Losing Weight with the AspireAssist.....	30
11.3	Other Tips for a Successful Aspiration .....	31
11.4	Troubleshooting.....	32
12.	LIVING WITH THE ASPIREASSIST .....	32
12.1	What to Expect During Follow-up Medical Appointments .....	32
12.2	Lifestyle Counseling and Group Meetings .....	33
12.3	When Do I Need to Have the AspireAssist Removed?.....	33
12.4	Your Patient Identification Card .....	34
12.5	Magnetic Resonance Imaging (MRI), Travel and Airport Security .....	34
12.6	Taking Medications .....	34
12.7	If You Get Pregnant or Are Planning to Get Pregnant .....	35
13.	ACCESSORIES REPLACEMENT.....	35
13.1	Connector.....	35
13.2	Tubing Set and Reservoir .....	35
13.3	Companion.....	35
13.4	Skin Port .....	36
13.5	A-Tube.....	36
14.	LIMITED WARRANTY .....	36
14.1	Limited Warranty .....	36
15.	SYMBOLS.....	37
16.	CONTACT.....	37

## Glossary

**Anesthesia:** A medication that takes away pain from part of your body or makes you sleep or feel sleepy so that you don't feel pain during a medical procedure.

**Anesthesiologist:** A doctor specializing in the use of anesthesia for medical procedures. An anesthesiologist gives you the medications and checks your health while the medication is in your body.

**Binge Eating Disorder:** A serious eating condition in which you frequently eat unusually large amounts of food and feel unable to stop eating.

**Body Mass Index (BMI):** A screening tool to measure body weight categories based upon height and weight.

- Below 18.5 - Underweight
- 18.5-24.9 – Normal or Healthy Weight
- 25-29.9 – Overweight
- 30 and above – Obese
  - 30 to < 35 – Class 1 Obesity
  - 35 to < 40 – Class 2 Obesity
  - 40 or higher – Class 3 Obesity

**Cholesterol:** A substance that is found in your blood. If you have too much cholesterol, it may start to build up in your blood vessels and may cause restricted blood flow, clots, or serious heart problems.

**Clinical Study:** A scientific trial to test new medicines or medical devices in a controlled way to find out how well they work.

**Component:** A part of the AspireAssist device, such as the Companion, Connector, or Reservoir.

**Diabetes:** A disease that affects the way your body handles glucose, a kind of sugar, in your blood.

**Endoscopy:** A medical test where your doctors look inside your body using an endoscope.

**Endoscope:** A long, bendable tube with a tiny camera attached. The doctor moves it down your throat to see inside your stomach.

**Endoscopic:** Using an endoscope for a medical test or procedure.

**Esophagus:** The tube that carries food and liquids from your mouth to your stomach.

**Fistula:** The path that the doctor makes from your stomach to your abdomen where the A-Tube is placed.

**Granulation Tissue:** Part of the healing process in which lumpy, pink tissue containing small blood vessels, forms around the edges of a wound. The stoma site is seen by the body as a wound and so the body tries to heal it causing this granulation tissue. With a stoma site, there may be a lot of granulation tissue and it can become irritated and may need treatment.

**Hypertension:** High blood pressure.

**Long term duration:** For the AspireAssist long term duration is defined as one year or more.

**Microorganisms:** A small living organism such as a bacteria, viruses, yeast or fungus. Our digestive system has many of these organisms that help in breaking down the food that we eat.

**Nutritionist:** A trained person who helps you plan what foods to eat that are good for your health.

**Obesity:** A medical condition in which extra body fat builds up to the point that it may be unhealthy. People with a BMI of 30 and above are obese.

**Peritonitis:** An inflammation or infection of the tissues of the abdomen causing fever and pain and can be life threatening if not treated.

**Sedation:** Medication used to make you feel sleepy and not feel pain during a medical test or procedure.

**Side Effect:** Something bad or harmful that can happen as a result of a medical treatment or medication that may or may not be expected.

**Stoma:** The area around where the A-Tube comes out of the skin is the stoma site.

## **Acronyms**

**APC** Argon Plasma Coagulation is a therapy that is used in preparing a stoma site for closure, and that may also be used to treat granulation tissue.

**PEG** Percutaneous Endoscopic Gastrostomy is a tube that is placed from the skin of the abdomen through to the stomach using an endoscope.

## 1. WELCOME

Congratulations on beginning your weight loss journey with the AspireAssist!

If you're like other AspireAssist patients, you've tried many diets that haven't worked for you long-term. The AspireAssist is different. It will take real time and effort, but if you follow a few basic principles such as chewing well, drinking plenty of water and aspirating, it can be the helping hand you need to reach life-changing weight loss and have a healthier lifestyle.

This manual will reinforce the training you received from your doctor and nurse and support your learning as you become accustomed to using your AspireAssist. If you have any questions or concerns, contact your doctor or nurse right away.

## 2. THE ASPIREASSIST SYSTEM

The AspireAssist is a tool to help reduce the amount of food that your body takes in. After you eat a meal, the device allows you to empty about 25-30% of the contents of your stomach into a toilet, so your body doesn't absorb those calories. This emptying process is called aspirating.

You will need to chew your food into small pieces in order to aspirate. With thorough chewing, you're likely to find that you eat more slowly and feel full sooner, which are good steps to take toward maintaining weight loss.

You should aspirate about 20 to 30 minutes after each meal. Waiting 20 to 30 minutes gives your stomach time to break down the food even further into a thick liquid so it will fit through the tube easily. If you wait too long, the food will be passed from the stomach into the intestines, and you will no longer be able to aspirate that meal. Although you may find that certain types of foods will require a longer or shorter period of time before they can be aspirated easily.

While you will learn healthier habits and change your diet over time through lifestyle counseling, there are no specific food or beverages that are "off limits". The key to losing weight with the AspireAssist is chewing your food into small pieces to ensure good aspirations after each major meal, (three times per day), while actively participating in lifestyle counseling.

The AspireAssist is intended as a long-term therapy, which means you would use the device for a year or more. However you may be able to reduce the number of times you aspirate each day as you get close to your target weight, begin to reduce portion sizes and make healthier choices.

There are two main sections of the system: 1) the parts that stay attached to your body are the A-Tube inside your stomach which is connected to the Skin-Port on your abdomen, and 2) the parts that are only connected when you aspirate including the Companion with the Tubing Set, the Connector and the Reservoir.

### 2.1 A-Tube™ and Skin-Port™

To start therapy, a thin flexible tube called the A-Tube is placed in your stomach and through your abdomen using an endoscope to go through your mouth, down your throat and into your stomach. The

A-Tube has five holes where small pieces of food in the stomach can enter the tube during the aspiration process. The A-Tube has a soft round bumper that sits against the inside wall of your stomach, designed to help prevent the A-Tube from pulling out of your body.

The tube connects to a button, called the Skin-Port, on the surface of your skin. The Skin-Port is a small plastic valve that you will open when you are ready to aspirate, letting the food empty straight into the toilet. The Skin-Port is attached to the A-Tube in a short office visit, about one week after you have the A-Tube put in. The Skin-Port will stay in place on your abdomen for as long as you have your A-Tube.

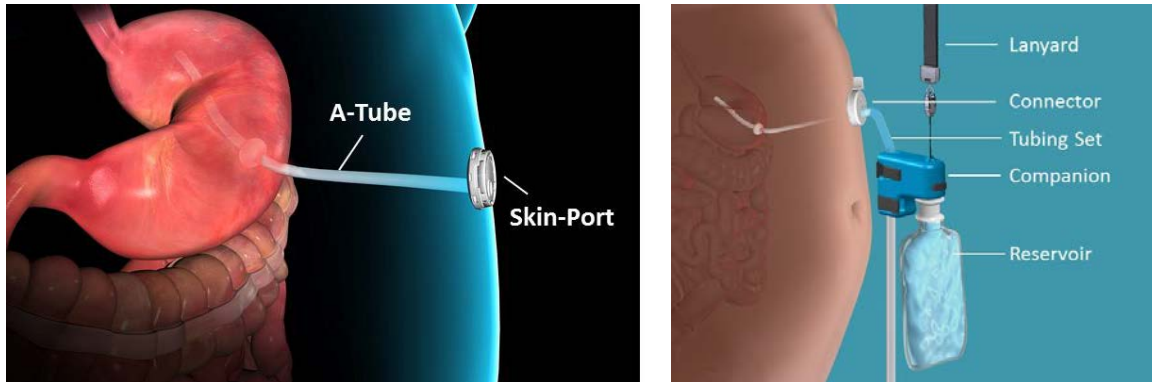

## 2.2 Companion™ and Accessories

To begin aspiration, the Companion and other parts are taken out of the Carry Bag and connected to the Skin-Port. The Companion is a small plastic device that fits into the palm of your hand, and allows you to control the flow of food aspirated. When the Drain Clamp on the Companion is open, liquid and small pieces of food will drain from the stomach into the A-Tube, then enter the Tubing Set and go straight down into the toilet. The device does not use any batteries or motor, and works by using gravity (simple draining).

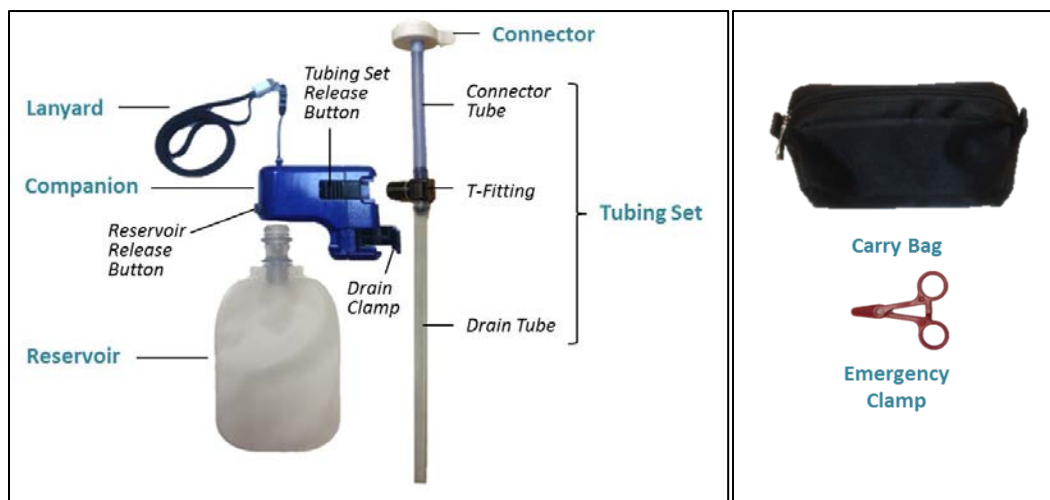

The part that attaches onto the Skin-Port is called the Connector. The Connector can be used 115 times before it will lock up (usually about 5-6 weeks when used about 3 times per day), and then it must be

replaced with a new Connector. There is a counter on the Connector that shows the number of uses left. You can only get new Connectors from your doctor or nurse when you go back for your follow up visits and regular medical checks. Be sure to bring your Connector to each of your follow-up visits. This helps your doctor make sure that the system is being used correctly.

The system also includes a flexible water bottle, called the Reservoir, which can be filled with regular drinking water (typically from a sink) and attached to the Companion. When the Companion clamp is closed, you can gently squeeze water into the stomach to help loosen bits of food.

After you finish aspirating, disconnect the Connector from the Skin Port. The device is only used during the aspiration process after each meal. All of these parts are then cleaned very well and stored back in the carry bag.

### 2.3 Emergency Clamp

You will also receive an Emergency Clamp with your system. The Emergency Clamp should be stored in the carry bag at all times until you need to use it.

**Warning:** If the Skin-Port disconnects from the A-Tube, or if there is a tear or leaking from the A-Tube, attach the Emergency Clamp to the A-Tube right way. This will keep the A-Tube in place and stop leaking of stomach contents or the A-Tube from slipping into the stomach. Contact your doctor as soon as you can, to put the Skin-Port back on or replace the A-Tube if necessary.



Open the Emergency Clamp, slide the A-Tube into the clamp and close until the handle latches.

## 3. WHO IS A CANDIDATE FOR THE ASPIREASSIST?

### Indication Statement

The AspireAssist® is intended to assist in weight reduction of obese patients. It is indicated for use in adults aged 22 or older with a Body Mass Index (BMI) of 35.0-55.0 kg/m<sup>2</sup> who have failed to achieve and maintain weight loss with non-surgical weight loss therapy. The AspireAssist is intended for a long-term duration of use in conjunction with lifestyle therapy and continuous medical monitoring.

## 4. WHO IS NOT A CANDIDATE FOR THE ASPIREASSIST?

There are medical issues that might mean the AspireAssist is not the right therapy for you. Your doctor will review the conditions below with you, so please tell your doctor if you have had any of these conditions in the past or are having them currently. Your doctor will decide if the risks of this procedure



or therapy are greater than the benefits in your case. You will not be a candidate for the AspireAssist if you have any of the following medical conditions:

- Certain disorders that cause extreme difficulty swallowing or digesting food
- Previous stomach ulcers that do not resolve with treatment
- High blood pressure than cannot be controlled with medication (blood pressure >160/100).
- Blood clotting disorders
- Pregnant or lactating
- Bulimia, Binge Eating Disorder, or Night Eating Syndrome
- Anemia
- Previous abdominal surgery that increases the risk of placing the A-Tube
- Serious pulmonary (lung) or cardiovascular disease, such as heart failure
- Chronic abdominal pain
- Physical disability, mental disability, or psychological illness that might prevent you from being able to use the therapy safely and successfully
- Poor general health or severe organ dysfunction, such as cirrhosis of the liver or kidney dysfunction

Your doctor will review your medical history to decide whether this procedure and therapy are safe for you, and whether you are likely to or will be able to benefit from the therapy. Your doctor may also decide during the first part of the endoscopy procedure, before any incisions are made, that the A-Tube cannot be safely placed.

## 5. SAFETY INFORMATION

### 5.1 Warnings

AspireAssist has not been studied to find out if it is safe for patients who have these conditions:

- Previous radiation therapy to the chest or abdomen, which may increase the risk of A-Tube placement
- Uncontrolled diabetes (hemoglobin A1C > 9.5%) or diabetes treated with insulin or sulfonylurea medications. These conditions may make it harder for the stoma to heal or to control your blood sugar
- Low blood potassium levels, which may make it harder to keep your potassium at a healthy level

#### Follow-Up Care

- You must return to your doctor's office for all scheduled follow-up visits while using the AspireAssist. Not getting regular medical checks while using the system could lead to serious problems. The A-Tube bumper could be pulled into the stomach wall causing a buried bumper and an endoscopic or surgical procedure may be needed to remove the A-Tube.

#### When to Seek Medical Attention

- You must return to your doctor if the Skin-Port begins to feel tight for any reason, or while you are in any position (seated, standing, etc.). The Skin-Port could feel tight if you gain weight or if it was not

connected right. Too much tension on the A-Tube from the Skin-Port could cause part of the A-Tube to pull into the stomach wall. This could cause a buried bumper and an endoscopic or surgical procedure may be needed to remove the A-Tube.

- You should see your doctor if you start to feel any new or worsening abdominal pain as this could be a sign of a more serious condition which may be related or unrelated to the A-Tube.
- The AspireAssist has not been studied to find out if it is safe for pregnant women or the baby. During pregnancy, your abdomen will expand and the Skin-Port could get too tight on your skin, causing serious complications. For example, the A-Tube bumper could be pulled into the stomach wall causing a buried bumper and an endoscopic or surgical procedure may be needed to remove the A-Tube. If you want to become pregnant, you will need to have your A-Tube removed before you become pregnant. If you become pregnant while your A-Tube is in place, tell your doctor right away. Your AspireAssist doctor and your obstetrician will make a plan to take out your A-Tube in a way that is as safe as possible for you and your baby.
- If the Skin-Port disconnects from the A-Tube at any time, attach the Emergency Clamp to the A-Tube right away to stop leaking of stomach contents and to keep the A-Tube from slipping into the stomach. Contact your doctor as soon as you can, to put the Skin-Port back on. See Section 2.3 for instructions on how to attach the Emergency Clamp to the A-Tube.
- If you notice irritation, redness, any change in discharge, or pain around the skin underneath the Skin-Port at any time, contact your doctor right away. It could be a sign of infection or other issue with the fistula tract. If the cause of the condition is not treated it could result in tissue damage.
- If you experience severe nausea and vomiting or diarrhea at any time, contact your doctor right away. Severe diarrhea means having more than 10 loose, watery stools in a single day (24 hours). Nausea and vomiting is considered severe if it occurs several times or for 48 hours or longer. Severe nausea and vomiting or diarrhea can lead to a dangerous loss of body fluids if not treated right away.
- If at any time during therapy you feel that you are eating unusually large amounts of food and feel like you cannot stop eating, you must contact your doctor right away. This behavior may be a sign of the onset of an eating disorder such as binge eating. If this is diagnosed, then you may need to stop aspirating for a time or possibly have the A-Tube taken out.

### Aspiration

- Until you have made major lifestyle changes, you should aspirate after the three major meals. As you lose weight, the length of the A-Tube where the Skin Port is attached, will be shortened by your doctor. Eating meals without aspirating could lead to gaining weight again. If a lot of weight is gained, part of the A-Tube could pull into the stomach wall because the tube is too short for the added belly fat. If this happens, an endoscopic procedure may be needed to take out or replace the A-Tube.
- Do not aspirate more than three times per day. Aspirating too much could lead to serious problems such as losing weight too fast which can cause a dangerous loss of body fluids or low potassium (a substance in the blood that controls important body functions). Rapid weight loss might also lead to gallstones.
- Only fill the Reservoir with drinking water (not flavored or bubbly), the same water that you would drink through your mouth. Use of contaminated or dirty water could make you sick causing vomiting

or diarrhea, or lead to severe illness or death if the contaminated water contains toxic chemicals or bacteria.

- If you are having a hard time aspirating (less food coming out when you aspirate) it may mean that the tube in the stomach has folded over or there is a clog in the tube. This could cause abdominal discomfort and less weight loss if not taken care of.
- Stop squeezing water from the Reservoir if you start to cough. This could mean that your stomach is too full and could make some of that liquid come up and then into your lungs and make you sick. Gently squeeze the Reservoir and only infuse a quarter to a third of the water at a time.

#### Care of the Skin-Port, Stoma Site, and Device

- Do not pull or twist the A-Tube or Skin-Port for the first week after you get it put in. Pulling or twisting on the A-Tube or Skin-Port can cause damage to the fistula tract, leaking stomach fluids, or burying the bumper into the stomach wall. A buried bumper may mean an endoscopic or surgical procedure might be needed to replace the A-Tube.
- Do not let the drain tube touch the water in the toilet or other dirty objects or surfaces. If the tubing set touches other parts of the system when you store it, they may become dirty as well. If this happens, wash the drain tube with soap and water before putting it in the Carry Bag for storage and later use. Use of dirty components could cause you to get sick.
- The Companion and other parts should be washed at least once each day using the cleaning instructions in Section 10. Food that is not cleaned from the device may clog the system making it hard to aspirate or may spoil or grow mold which may be pushed into your stomach causing you to get sick.
- Do not insert any objects between the Skin-Port and the skin other than gauze pads, always lay flat not rolled, because this may cause irritation to the skin around your stoma or damage to the A-Tube such as a tear or hole. This may cause leaking of stomach contents, irritation of the stoma site and may require a new A-Tube.
- Do not use objects (e.g. wires or brushes) to clean the A-Tube or clear a clog in the tube. Using such objects may cause damage to the stomach such as injury to the stomach wall or may put a hole in your stomach and cause an infection.
- Try not to carry packages, objects, or children against your abdomen where the Skin Port sits. Pressing on the Skin-Port could cause pulling or twisting of the A-Tube that can cause damage to the stoma such as leaking of stomach fluid, bleeding or irritating the skin around the A-Tube.
- Do not try to open the Skin-Port valve except with the Connector. If the Skin-Port valve is partly opened, stomach contents can leak and cause skin irritation.
- If the device leaks stomach content onto your skin, rinse the area with water and pat dry to stop skin irritation. Stomach contents are very acidic and may irritate the stoma site as well as the skin and may cause burning or discomfort.

#### Prescription Medication

- If you are taking prescription medicine, please talk to your doctor to figure out if the dose should be changed as you lose weight loss. Some medication dosage is based on your weight and if your weight

changes, the dosage could probably change too. Otherwise you may be taking too much or too little medicine to properly treat your condition.

- You should take your medicine at least **2 hours** before aspirating. This is to keep the medicine from being aspirated. If your medicine is aspirated you may not receive the full benefit of the medicine and the condition that it is treating may get worse. For example, you could have an increase in blood pressure because the whole dose of medicine was not digested before you aspirated. You can also take some medicine right after aspirating or at bedtime. If medicine has to be taken with food or with your main meals, you may be able to take it right after aspirating, since most of your meal will still be in your stomach. You should work with your doctor to figure out the best schedule for taking your medicine.

## 5.2 Cautions

- You must be in a standing position with the Companion below the Skin Port for food and liquid to drain from your stomach, because the system works by gravity.
- Only the Connector should be attached to the Skin-Port, otherwise the Skin Port could be damaged and need to be replaced before you can aspirate again.
- Look at the Companion, Connector and Skin-Port to see if there is any visible damage before connecting them together to start aspiration. If you notice any damage, replace the broken part before you use it as the broken part may leak stomach contents that will need to be cleaned up.
- Do not try to take the Companion apart. Tampering with the Companion could cause the device to leak stomach contents requiring cleanup.
- When putting together or taking apart the Connector from the Skin-Port, if the Connector lever gets jammed, do not push the lever harder as this may break it and the Connector won't work and you won't be able to aspirate. If you can, take the Connector off and start the process over. If this doesn't work, use the Emergency Clamp to stop leaking of stomach contents, take the blue Connector tubing off and call your doctor for help as soon as you can.
- The Emergency Clamp should be stored in your carry bag at all times until you need to use it. If the Skin-Port disconnects from the A-Tube at any time, attach the Emergency Clamp to the A-Tube right away to stop leaking of stomach contents and to keep the A-Tube from slipping into the stomach. Contact your doctor as soon as you can, to put the Skin-Port back on. See Section 2.3 for instructions on how to attach the Emergency Clamp to the A-Tube.
- If the A-Tube develops a leak or tear behind the Skin Port the Emergency Clamp should be used to stop leaking of stomach contents and to make sure the tear or leak does not get worse. Contact your doctor as soon as you can to shorten or replace the A-Tube.
- Do not use the following liquids to clean the device: alcohol, ethanol, bleach, acetone, hydrogen peroxide, or household/multi-purpose cleaners. Use of any of these liquids may damage the plastic components and labeling, and may cause harmful chemicals to be pushed into the stomach when used later. Only use dish soap, baking soda in water or vinegar and water, as described in Section 10.3.

- Never put the Companion, Reservoir, or other parts in the dishwasher, boiling water or a microwave oven. This may cause the plastics to melt or change shape and the components will not be useable.
- Do not use objects (e.g. wires or brushes) to clean the A-Tube or Skin-Port. Using such objects might cause damage to the components such as a tear or hole which may result in leaking of stomach contents, irritation of the stoma site and possibly require replacement of the A-Tube.

## 6. RISKS AND BENEFITS

A U.S. clinical study was performed with the AspireAssist on 171 patients. Two out of three patients were chosen by chance for the treatment group. This group received the AspireAssist and was given lifestyle counseling. One out of three patients was assigned to the control group who got only lifestyle counseling. The study was called the PATHWAY Study and was done at 10 hospitals in the United States for one year. The patients in the study were adults who had a BMI of 35 – 55 at the start of the study. Patients were not allowed to be in the study if they had any of the health conditions described in Section 4, such as uncontrolled Type 2 diabetes or high blood pressure, or if they were pregnant or planned to become pregnant during the study. All of the patients were seen every four to six weeks for checkups and to see how they were doing with the therapy.

### 6.1 Risks Associated with the AspireAssist

There are risks associated with the AspireAssist. Some of these risks are related to the A-Tube placement procedure, and some risks are due to the AspireAssist device or therapy.

#### Serious Side Effects

The PATHWAY study examined the risks that may be related to AspireAssist, including the risks of the A-Tube placement procedure, and the risks of the AspireAssist device or therapy. These events are described here and in **Table 6-1** below. During the 12 month study, 4 of the 111 treatment patients (3.6%) experienced a serious adverse event related to the treatment. A serious adverse event is defined as needing a hospital visit or IV medications to treat the problem the patient was having. Of these four patients, one patient had abdominal pain after the procedure and returned to the emergency room for pain medication; one patient had peritonitis (inflammation of the tissue that lines the abdomen) and stayed overnight at a hospital for medical testing and was given antibiotics; one patient had a non-bleeding ulcer, or sore, on the inside of the stomach and had the A-Tube removed; and one patient had the A-Tube replaced because the Skin-Port was not attached right. These events were all resolved within 3 days and successfully treated with no long-term complications. There were no deaths in the study. The following table shows the procedure and device related serious side effects (serious adverse events) that were reported with the AspireAssist during the study.

**Table 6-1 Serious Side Effects with AspireAssist that were seen in the US Study**

Serious Side Effect	Number of People who had that side effect in the US study	Harm or possible harm	When the side effect happened
<b>Side Effects Related to the Procedure</b>			
Peritonitis (mild pneumo-peritoneum without abscess)	1 out of 111	Inflammation of tissue which lines the abdomen which can lead to infection and severe pain	3 days post A-Tube placement procedure
Abdominal pain post procedure	1 out of 111	Pain in the area where the stoma was created	Day of A-Tube placement procedure
<b>Side Effects Related to the Device</b>			
A-Tube Replaced (A-Tube was replaced due to normal wear)	1 out of 111	Scheduled endoscopic procedure	54 weeks post A-Tube placement
Non-bleeding pre-pyloric ulceration	1 out of 111	Sore on the inside of the stomach which can result in pain	53 weeks post A-Tube placement

**Table 6-2 Serious Side Effects which were not seen in the study but are known to occur with gastrostomy tubes**

Possible Serious Side Effects	Potential Harm from the Event
<b>Side Effects Related to the Procedure</b>	
Complications of conscious sedation	Slowed breathing, blockage in the throat, changes in blood pressure may be experienced and may require medical treatment to prevent severe injury or death
Sore throat (severe pain)	Difficulty swallowing
Hypoventilation	Shallow breathing which may require oxygen or a tube placed in the throat
Aspiration pneumonia (breathing liquid into the lungs causing an infection)	Pneumonia requiring antibiotic treatment and if not treated could lead to death
Perforation of the throat or stomach during the endoscopic procedure	Bleeding, pain, possible infection and surgery may be needed to repair the injury. If not treated could lead to death.
death	
<b>Side Effects Related to the Device</b>	
Gastric erosion (sores on the lining of the stomach)	Pain which may require treatment with stomach acid reducing medication or potentially removal of the A-Tube
Difficulty sleeping on the abdomen	Sleeping on the abdomen might cause tugging or pulling on the Skin Port resulting in irritation to the stoma or leakage
Reduced range of motion around the abdomen	Discomfort may be experienced with bending or twisting at the waist
Scarring or skin indentation after tube removal	Patient may be uncomfortable exposing this area.
<b>Side Effects Related to the Therapy</b>	
Changes in iron level in the blood	Weight loss may cause an increase in menstruation in female patients
Calcium supplements and a more organized exercise plan to protect bone health	Weight loss may cause loss of bone density particularly in patients over the age of 65 or at risk for osteoporosis.

Adverse Events Reported in the U.S. Clinical Study

All non-serious side effects related to the AspireAssist are described in **Table 6-3** below. These events were mainly short-term, and resolved within one week with treatment.

**Table 6-3 Non-serious side effects with AspireAssist seen in the US study**

EVENT	NUMBER (PERCENT) OF PATIENTS WHO EXPERIENCED EVENT	HARM OR POSSIBLE HARM
Granulation tissue around stoma (lumpy pink tissue which grows around the stoma edges and may become irritated and painful)	45 out of 111 (40.5%)	44 subjects described as mild and treat topically with silver nitrate sticks or medicated lotion  1 subject had significant granulation tissue that was treated endoscopically using Argon Plasma Coagulation
Abdominal pain after procedure	41 out of 111 (36.9%)	Pain in the stomach or at the stoma site  41 subjects had mild or moderate pain that was treated with medication which could include narcotic painkillers
Nausea or vomiting	19 out of 111 (17.1%)	Feeling dizzy which may cause a fall or throwing up and losing body fluids, caused by the sedation medicine, resolved without treatment or with anti-nausea medication which could be given by injection
Irritation around stoma	19 out of 111 (17.1%)	Redness or puffiness around the stoma, resolved without treatment as stoma site healed and with proper stoma site care
Abdominal discomfort (intermittent – discomfort may come and go, or may be present for a short period of time and then go away)	18 out of 111 (16.2%)	Unpleasant feeling around the stomach resolved without treatment
Possible infection (symptoms were not confirmed)	15 out of 111 (13.5%)	Pus or oozing from the stoma site sometimes with a fever, resolved with antibiotics
Abdominal pain >4 weeks after procedure	8 out of 111 (7.2%)	Longer term pain in the stomach or at the stoma site, treated with medication
Upset stomach (acid reflux, heartburn, hiccups, belching)	7 out of 111 (6.3%)	Acid reflux, heartburn, hiccups, belching, no potential harm, resolved with over the counter antacids
Swelling around the stoma	6 out of 111 (5.4%)	Puffiness or redness around the stoma, resolved with healing of the stoma and proper stoma site care
Fluid leaking around stoma	5 out of 111 (4.5%)	Drainage could irritate the stoma causing pain and discomfort, resolved with healing of the stoma and reducing movement and tension on the A-Tube
Changes in bowel habits (constipation, diarrhea)	5 out of 111 (4.5%)	Stools that are dry and hard to pass causing pain or discomfort, or liquid stool more

		than 3 times a day causing loss of body fluids resolved with dietary changes and over the counter medications
Low potassium in the blood	4 out of 111 (3.6%)	May cause cramping in the legs or feet treated with potassium supplements
Accidental pulling or bumping of the A-Tube	3 out of 111 (2.7%)	May cause pain or leaking at the stoma site resolved by protecting the Skin Port from contact
Bleeding at the stoma	2 out of 111 (1.8%)	Blood at the stoma site resolved by treatment of granulation tissue and proper stoma site care
Fungal infection at the stoma	2 out of 111 (1.8%)	Pus or oozing from the stoma site, resolved with topical antifungal lotion
Broken veneer on front tooth (veneer is a layer of material used to cover a tooth for appearance or protection of the tooth)	1 out of 111 (0.9%)	Potential harm is tooth pain or sensitivity if the veneer is not replaced.
Bumper in the stomach moving into the stoma	1 out of 111 (0.9%)	Leakage from the stoma site and could require surgery to remove, reinforcing that the Skin Port should not be tight against the stomach which could be caused by weight gain, or by pulling on the Skin Port
Bruise near the stoma	1 out of 111 (0.9%)	Pain if touched, no harm, resolved without treatment
Fever	1 out of 111 (0.9%)	High body temperature may cause chills or tiredness, treatment with antibiotics
Air in the abdomen from the procedure	1 out of 111 (0.9%)	Discomfort until the air is absorbed, no harm, resolved without treatment
Ulcer at the stoma	1 out of 111 (0.9%)	A sore at the stoma site resolved with proper stoma care
Stoma would not close without treatment when the A-Tube was removed	1 out of 111 (0.9%)	The stoma may require treatment to the inside of the fistula tract and maybe clips or stiches to sew the stoma closed inside the stomach
Fluid swelling in both legs	1 out of 111 (0.9%)	May be a risk in patients who are on medications that increase the removal of water from the body which need to be stopped just for the procedure
Pain in the hand	1 out of 111 (0.9%)	Possible harm is muscle fatigue due to squeezing the Reservoir, new design resolved this issue
Acid reflux pain	1 out of 111 (0.9%)	Discomfort, treated with antacids
Stomach spasms	1 out of 111 (0.9%)	Cramps in the stomach resulting from diarrhea treated with over the counter medications

### Study Withdrawals

Of the 111 treatment patients, 29 had their A-Tube removed before 12 months. As shown in the Table 6-4 below, of these 29, 1 A-Tube was taken out because of abdominal discomfort, 22 were due to the patient's decision, 5 patients moved away from the area, and 1 subject had unrelated health issues.



**Table 6-4: AspireAssist Subject Withdrawals**

# of Subjects	Reason for withdrawal
5	Subjects moved out of state; no site near new location.
1	Medical reasons unrelated to therapy
2	Family issues caring for children resulting in lack of time or discomfort from the A-Tube due to a young child tugging on the tube
15	Lack of time to aspirate, no motivation
3	Nausea, Discomfort, Lack of time or motivation
1	Subject and spouse felt device interfered with intimacy
1	Poor Results Lack of Weight Loss Efficacy
1	Abdominal discomfort, subject withdrew because of pain. Unwilling to take medication to relieve pain.

## 6.2 Benefits of the AspireAssist

In the U.S. clinical study, the 111 patients who were treated with the AspireAssist lost an average of 31.3 pounds in the first year. The 82 patients who completed one year of therapy lost an average of 36.6 pounds. Patients in the AspireAssist treatment group lost significantly more weight than the patients in the control group. These results are shown in Table below.

**Table 6-5 Average Weight Loss of All Patients Who Received Treatment**

Treatment Group	Number of Patients	Average Weight Loss in Pounds	Average Weight Loss in Kilograms
AspireAssist	111	31.3	14.2
Control (lifestyle therapy only)	59*	9.0	4.1

\*1 of 60 total control patients withdrew from study after first visit, and is not included in results

**Table 6-6 Average Weight Loss of All Patients Who Completed 52 Weeks\***

Treatment Group	Number of Patients	Average Weight Loss in Pounds	Average Weight Loss in Kilograms
AspireAssist	82	36.6	16.6
Control (lifestyle therapy only)	31	12.6	5.7

\*Includes all treated subjects who completed the scheduled follow-up visits up to and including 52 weeks.

Scientific research shows that weight loss in obese patients with type 2 diabetes helps to control the disease. Research also shows that weight loss improves the major risk factors for heart disease, such as high bad cholesterol (HDL), low good cholesterol (LDL), and high blood pressure<sup>1</sup>.

Other benefits of the AspireAssist are that it is a 15 minute outpatient endoscopic procedure, so no surgery is needed. The A-Tube can be taken out at any time and the stoma will close with no permanent changes to your body.

With the AspireAssist, you can make slow and steady changes to your diet and exercise routines while you are losing weight. Lifestyle counseling is provided to help you make those changes at your own pace.

### **6.3 Aspire Pathway Post Approval Study Summary**

#### Study Design

The Pathway Post Approval Study (PAS) is a multicenter, single-arm prospective, active surveillance study designed to gather long-term data on the frequency, duration, and severity of adverse events, weight loss, compliance with AspireAssist therapy, impact of AspireAssist therapy on eating behavior and the effectiveness and safety outcomes after the device is removed. This study followed patients from the PATHWAY pivotal study for five years after they were implanted. Patients who had the device removed were followed for two years after removal.

#### Study Population

At the end of the Pathway study there were 31 patients who were eligible and agreed to participate in the extended follow-up PAS. Of these 31 patients, 30 had the A-Tube in place and were undergoing active therapy, while 1 was in post-explant follow-up.

#### Data Source

The data comes from the electronic Case Report Forms filled out by the study coordinator with information about visits, physical and psychological examinations and laboratory data.

#### Key Study Endpoints

##### Safety Endpoints

The safety of the device is evaluated by: how many side effect the patients have; how often there are serious problems; and if anyone develops any type of eating disorder.

##### Effectiveness Endpoints

How well the therapy is working is based on how much weight patients lose and if things like blood pressure, cholesterol and diabetes HbA1c improve; or if the patient can come off of some medications.

---

<sup>1</sup> Anderson et al. Obesity and disease management: effects of weight loss on comorbid conditions. *Obes Res.* 2001 Nov; 9 Suppl 4:326S-334S.

### Total number of Enrolled Study Sites and Subjects, Follow-up Rate

Seven (7) sites continued in the PAS study. There were a total of 31 patients who signed up.

### Study visits and length of follow-up

Study visits were quarterly (every 13 weeks) for medical monitoring, which includes metabolic, psychological and physical assessment occurred from the end of the first year through the end of year 5.

If the patient had the tube removed they had bimonthly visits for the first 6 months and then at 1 year and 2 years after the tube was removed.

### ***Summary of the Post-Approval Study Results***

#### Final safety findings

Over the 5 years of the study there were no new issues that had not been seen before. Also, after the first year there were fewer events. This shows that the majority of issues were a result of placing the A-Tube. In the Post Approval Study there were two reports of irritations in the stomach from the tube. It seems the A-Tube had turned towards the bottom of the stomach. This is rare but can be detected because there isn't much aspiration flow. A-Tube position can be seen in an x-ray to check. The most frequent issue is that stoma sites can take longer to heal. This can happen when the tube is in place for more than a year. Aspire has recommendations for the physicians when they take the tube out about how to treat the stoma to help it heal.

The following table describes the problems that patients had during the 4 years of the PAS.

#### **Adverse Events**

<b>Description</b>	<b>n Patients</b>	<b>N Events</b>
<b>Related to the Device</b>		
Gastric ulcer noted during A-Tube replacement	1	1
Cellulitis related to inadvertent trauma to A-Tube	1	1
Peristomal inflammation	1	1
Persistent fistula	4	4
Gastric and duodenal ulcers and erosions	1	1
Bacterial infection, peristomal	1	1
Peristomal leakage	1	1
<b>Related to the Procedure</b>		
Superficial mucosal tear, occurred during A-tube replacement	1	1
<b>Related to the Therapy</b>		
None	0	0

There was one serious issue where the patient damaged the A-Tube and had it removed earlier than planned.

No patients reported eating disorders or showed any signs when evaluated using the standard Eating Disorder Evaluation or Questionnaire on Eating and Weight Patterns during the Post Approval Study.

#### Final effectiveness findings

The effectiveness of the therapy is evaluated based on weight loss. For the 10 patients who completed all 5 years of the study the average weight loss was 65 pounds with a range of 10.8 to 147.2 pounds,

**Average Weight Loss of All Patients Who Completed 5 Years**

Treatment Group	Number of Patients	Average Weight Loss in Pounds	Average Weight Loss in Kilograms
AspireAssist	10	65.0	29.5

Effectiveness is also evaluated based on changes in obesity-related health issues like blood pressure, lipid levels, cholesterol, diabetes HbA1c, and a decrease in the number of medications taken for these health problems. There is improvement in most measures from year one to year 5. Six of the 10 subjects who finished the study were medication free by year 5.

#### Post Explant Follow-up Results

There were 20 subjects who had the A-Tube removed during the Post Approval Study, and one additional subject who was in post explant follow-up when they enrolled. 7 subjects completed the first year post explant follow-up and 3 subjects completed the year 2 post explant follow-up. It is difficult to draw any conclusions with so few data points. In general, all subject stoma sites were healed, there was a decrease in weight loss over the two years. There were no indications of any eating disorders over the period. Subjects did maintain improvements made in HbA1c and Impact of Weight on Quality of Life Questionnaire (IWQOL) indicating that subjects continued to have an improved sense of wellbeing two years after leaving therapy.

#### Study Strength and Weaknesses

The strengths of the Post Approval Study are the long term safety and effectiveness results which are consistent with the PATHWAY study. There were no new long term issues, and the issues which occurred were anticipated and consistent with what has been seen for the therapy as well as in standard PEG tube usage. The frequency, severity and duration of events in years 2 through 5 were markedly less than seen in the first year of the study. This confirms that the most frequent issues with the therapy are related to the procedure used to place the A-Tube, primarily abdominal pain and discomfort. The data also shows that the therapy provides sustained weight loss and modest improvements in health issues related to obesity over the duration of the study.

The primary weakness is the small number of subjects remaining in the study at the end of 5 years. There were 20 subjects who withdrew from therapy over the course of the study leaving 10 subjects who completed the 5 years. Of the 20 subjects that withdrew 7 completed the 1 year post explant follow-up and 3 completed the 2 year visit.

## 7. IS THE ASPIREASSIST RIGHT FOR ME?

The AspireAssist works differently than other weight loss methods, but just like other weight loss methods, it requires a real commitment. With the AspireAssist, you need to aspirate regularly and change your eating behaviors. Please consider the questions below, and take the time to talk through each question with your doctor, and if possible, with other patients who have used the AspireAssist.

- Can you spend 10-15 minutes to aspirate after each major meal, usually three times a day? It may even take longer than 15 minutes in the beginning, until you get used to the device and how to chew well.
- Does your schedule, your office setup, or home responsibilities allow you to leave to aspirate about 20 to 30 minutes after you eat?
- Where will you aspirate? Please think about the location and types of restrooms near to you throughout the day.
- If necessary, would you be comfortable aspirating in a public or shared restroom? Please take the time to discuss with your doctor or current patients what this is like.
- Do you have people in your life to support you in your weight loss journey? Support is very important for success with any weight loss method.
- Will you be comfortable with having a small button like Skin-Port on your abdomen for as long as you are using the AspireAssist? Although the Skin-Port is small and can usually be covered under your clothing, please think about things like wearing a swimsuit or during intimacy.
- If you have a partner, is your partner comfortable with you having a Skin-Port?
- Are you willing and able to chew your food very well, to stop food from clogging during aspiration? Think about the added time you need to eat your food very slowly and carefully. If you have dentures, do they fit well? This is key to successful aspirations.
- Are you willing to making slow and steady lifestyle changes during the course of therapy, including healthier food/drink choices, smaller portion sizes, less snacking, and increased exercise?
- Can you make the time to travel to all your follow-up doctor visits?
- For women: Do you understand that if you decide to get pregnant, the tube has to be taken out before you get pregnant? See Warnings section for details.

## 8. WHAT TO EXPECT BEFORE AND AFTER THE PROCEDURE

### 8.1 First Meeting with your Doctor

When you first meet with your doctor, you will be asked questions about your medical history to make sure that the procedure is safe for you. Please review the sections “Who is a Candidate for the

AspireAssist” and “Who is Not a Candidate for the AspireAssist” to learn more about the questions your doctor will ask you. Your doctor may also do a medical exam and take a blood sample during this visit to check for certain conditions such as high blood pressure, uncontrolled diabetes, and low potassium levels that could make the procedure or therapy less safe for you.

Your doctor will also discuss the time it takes and lifestyle changes needed to be successful with this therapy. Make sure you review the section “Is the AspireAssist Right for Me?” to get ready for this discussion, including any questions you may want to ask. It is also helpful to talk to other patients who have used the AspireAssist before you begin therapy, to make sure you understand the benefits, risks and the level of commitment needed with this therapy.

## **8.2 Your Procedure Day**

Your doctor will give you specific instructions to prepare for your procedure day. The A-Tube Placement procedure is typically an outpatient (same-day) procedure. Usually the procedure can be done with monitored sedation, which includes one or more medications to help you relax (a sedative) and to block pain (an anesthetic) to make the procedure comfortable for you. After monitored sedation, you may feel drowsy and not remember much about your procedure. Your doctor may decide before or during the procedure to use a deeper level of sedation. Discuss this possibility with your doctor.

The procedure will take about 15 minutes. During this procedure, your doctor will insert an endoscope, a thin flexible tube with a tiny camera at the end, into your mouth and down into your stomach to see inside your stomach. Your doctor will make a small ½ inch (1 cm) cut on your abdomen, then insert a long needle to access your stomach from the outside of your abdomen. Your doctor will then pass a thin flexible wire through this needle puncture into your stomach, then use the endoscope to pull it out through your mouth. Next, your doctor will use this wire to gently pull the A-Tube through your mouth, into your stomach, and out through your abdomen until the A-Tube bumper rests against the inside of your stomach.

After the procedure, you will have a long tube coming out of your abdomen. The new opening in your abdomen where the A-Tube is placed is called a stoma. This tube will be held onto your abdomen with tape to keep it in place while the stoma heals. The tube will be shortened to the surface of your skin about a week after the procedure. Patients can usually go home within 2 hours after the procedure. You will be given antibiotics and pain medications to take for several days after the procedure.

## **8.3 Recovering from the Procedure**

You should plan to take it easy for several days after the procedure. Although the procedure is minimally-invasive, many patients have pain or discomfort afterwards. You may take acetaminophen (Tylenol) as prescribed, if needed.

**Warning: Do not** use non-steroidal anti-inflammatory drugs (NSAIDS) such as aspirin, ibuprofen (Advil and Motrin), and naproxen sodium (Aleve). Because an incision was made to create the stoma for the A-Tube there is some potential for bleeding if these NSAIDS are used during the first few days.

If needed, a prescription pain medication can help make you more comfortable during your recovery.

Most patients can return to normal activities within two to three days, but some patients take up to a week or more to feel better.

You should not shower for 48 hours after the procedure to protect the stoma site from possible infection, however you may sponge bathe, protecting the tube site. After 48 hours, you may begin showering, but you should keep the stoma site dry by covering the A-Tube and surrounding area with a waterproof covering with adhesive borders to protect the stoma site from possible infection during the healing

**FAQ: A few days after my procedure, I noticed a small amount of fluid coming from the stoma site. Is this normal?**

During your recovery, you may have drainage around the stoma site, which will look like a small amount of fluid or blood discharge. This is part of the normal healing process, and may continue for several weeks after the procedure. Some people experience this discharge for longer. If the drainage increases or is foul smelling, contact your physician.

process. After showering, remove the covering and gently wipe around the site with mild soap and water, and pat the stoma site dry with a towel afterwards. You should not take a bath, swim, or use a hot tub until your doctor tells you it is okay. These activities could increase the risk of infection while the stoma site is healing. Your doctor will also give you detailed instructions on caring for your stoma during this time. It is very important to make sure any gauze pads used around the stoma are changed regularly to keep the area dry.

***Warning: You should contact your doctor right away if you have:***

- A fever with an oral temperature above 99°F (37.2° C)
- Severe pain even when taking pain medication
- Leakage of fluid or blood around stoma which quickly soaks the gauze
- A-Tube feels tight or is pulled out of the stomach
- T-Bar or bolster is too tight against your skin

These may be symptoms of an infection like peritonitis or too much tightness of the A-Tube causing the bumper to pull into the stomach wall. If the A-Tube is pulled out it must be replaced right away because the stoma will begin to close very quickly.

#### **8.4 Skin-Port Placement**

About one to two weeks after the procedure, your doctor will check that the stoma site has healed enough. The Skin-Port will be attached to the end of the A-Tube on the surface of your skin. This simple pain-free step takes just a few minutes and is done in the doctor's office. Your doctor will look at your stoma site to see how it is healing and tell you when you may begin AspireAssist therapy. If your Skin Port is attached earlier to reduce discomfort then you may begin AspireAssist therapy usually in about one more week. Beginning therapy right away may result in some discomfort or may slow the healing process in some patients.

## 9. USING THE ASPIREASSIST

Before your first use, the tubes and lanyard will be cut to the right length by your doctor or nurse. This helps make the device comfortable for you to use and keeps the drain tube from touching the water in the toilet. After the device has been fitted for you, review the parts of the device and how it works with your healthcare team.

### 9.1 AspireAssist Set-Up

**Step 1:** Attach the Connector Tube and Drain Tube to the T-Fitting,

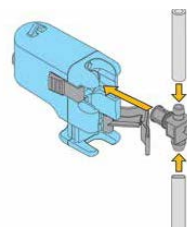

**Step 2:** Insert the T-Fitting into the Companion with the arrow pointing down.

**Step 3:** Close the Drain Clamp.

**Step 4:** Hang the Companion around your neck using the lanyard.

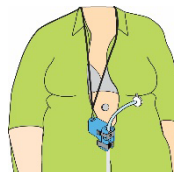

**Step 5:** Fill the reservoir with lukewarm drinking water. Do not over fill the reservoir. Leave a small amount of air in the neck of the bag.

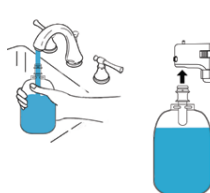

**Step 6:** Attach the Reservoir to the bottom of the Companion until the device “clicks”, which tells you it’s attached.

**Step 7:** Point the Drain Tube over the toilet, above the water. Don’t let the Drain Tube touch water.

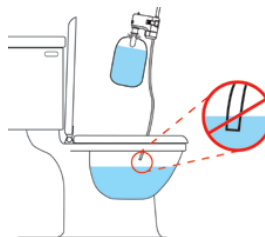



## 9.2 Attaching Your Device to the Skin-Port

Make sure the Drain Clamp is closed before attaching the Connector to the Skin-Port. Otherwise, stomach contents might start draining before you are ready.

**Step 1:** Push Connector (A) onto Skin-Port (B) until the Connector “feet” (C) contact the face of the Skin-Port.

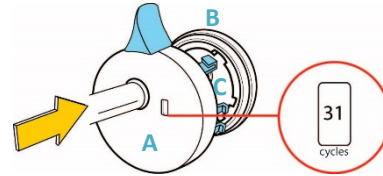

**Step 2:** Gently turn the Connector clockwise until the “feet” fall into the port holes and the Connector fits into the Skin-Port like a puzzle.

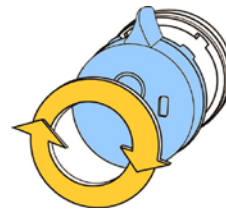

**Step 3:** Hold the Connector tightly with one hand and use the other hand to gently push the Connector lever (D) clockwise around the Connector.

**Do not force the lever. If it does not turn easily, disconnect and start over.**

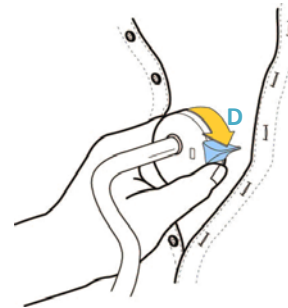

**Step 4:** Continue to push the Connector lever until it stops, then the Skin-Port valve is fully open.



**Note:** The Connector counts down, so it should now show a number one less than before it was attached. When the Counter reads “00”, you have completed 115 cycles and you will need to get a new Connector from your doctor. If you try to use the Connector again, it will then read “-9” (the number 9 with a minus sign in front of it) and lock up to keep you from using it again without seeing your doctor.



### 9.3 Aspirating Your Stomach Contents

**Caution:** You must be in a standing position with the Companion below your abdomen for your stomach to drain because the system works by **gravity**.

**Warning:** Stop squeezing water from the Reservoir if you start to cough. This could mean that your stomach is too full and could make some of that liquid come up into your lungs and make you sick. Gently squeeze the Reservoir and only infuse a quarter to a third of the water at a time.

**Step 1:** Open the Drain Clamp to start draining stomach contents out of Skin-Port, through the Connector Tube, and down the Drain Tube into the toilet.

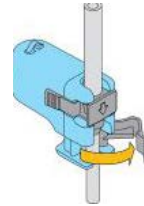

**Step 2:** When flow stops, close the Drain Clamp.

**Step 3:** Gently squeeze the Reservoir to push water into your stomach. Use about a quarter of the Reservoir so that you don't feel overfull and uncomfortable.



*Tip: Try changing body position or squeezing abdominal muscles to re-start flow prior to squeezing water in.*

**Step 4:** To restart draining, open the Drain Clamp. Repeat Steps 2 and 3 as necessary until there is no more food visible in the liquid that is draining.

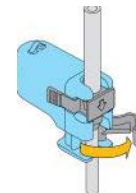

**Step 5:** After your stomach feels empty, push the Connector lever counter-clockwise until it stops. Then you can pull the Connector away from the Skin-Port.

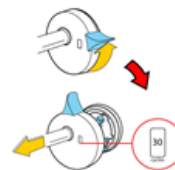

#### FAQ: How do I know when I have finished aspirating?

When you see no more food coming out and only liquid draining, you have finished aspirating. If little or no water goes into the stomach or comes out, you might have a clog and may not be able to finish aspirating. See the “Troubleshooting” section. Patients say that as they get more experienced with the therapy, they can feel when they are finished because their stomach feels empty. It will take some time to learn what works best for you.

## 10. DISASSEMBLING AND CLEANING YOUR DEVICE

### 10.1 Rinsing After Each Use

**Caution:** Companion, Connector Tube, Drain Tube, and T-Fitting should be rinsed after each use by following the procedure below.

#### Disassembly:

**Step 1:** Open Drain Clamp and press Tubing Release button to remove T-Fitting and tubing.

**Step 2:** Press reservoir release button to release Reservoir.

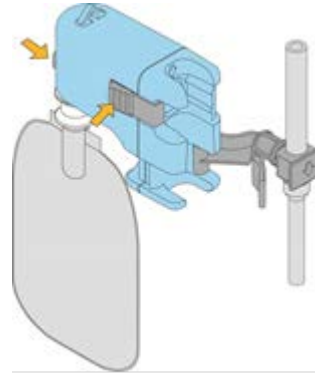

#### Rinse:

**Step 3:** Rinse all components in the sink and run drinkable water through the tubing.

**Step 4:** Wipe components dry with a paper towel, then store in carry bag.



### 10.2 Daily Cleaning

The Companion and accessories should be cleaned **at least once a day**.

**Warning:** The device **should not be connected** to the Skin-Port while cleaning the device. If the device is connected to the Skin Port while cleaning, soapy water could go into your stomach and make you sick (vomiting or diarrhea). Do not wash any part of the device in the dishwasher.

1. Fill the Reservoir with lukewarm water from the faucet with a few drops of dish soap
2. Attach the Reservoir to the Companion.
3. Attach the Tubing Set with the Connector to the Companion.
4. Close the Drain Clamp and hold everything over a sink.
5. Squeeze the Reservoir until about a third of the soapy water from the Reservoir has been pushed through the Connector and into the sink.
6. Open the Drain Clamp.
7. Squeeze the Reservoir again and push the rest of the soapy water through the Drain Tube and into the sink.
8. Rinse the soap out of the Reservoir.

9. Refill the Reservoir with water from the faucet. Repeat steps 3 & 4 one time.
10. Take the tubing set off and rinse everything with water to get rid of all of the soap / bubbles that you can see.
11. Wipe down the Companion with a towel, then allow everything to air dry.

### 10.3 Occasional Cleaning

A mix of vinegar and water or baking soda and water soak can be used as an alternative to water alone or soap and water (every 1-2 weeks) to remove bad smells from the Companion and other parts.

**Vinegar Soak:** Soak the Companion, Reservoir, T-Fitting, Connector Tube, and Drain Tube in a mixture of half household vinegar (distilled white vinegar) and half water overnight.

**Caution:** *Do not clean the Connector with vinegar*, as it could cause damage to the Connector.

Rinse all components in water before using.

**Baking Soda Soak:** Also, you may find that using a baking soda soak helps to remove bad smells. Mix 1-2 tablespoons of baking soda in a bowl of lukewarm water from the faucet (1 to 2 cups), and soak the Companion and other parts overnight. Rinse all components in water before using.

**Tubing:** If the tubing begins to slip off of the T-Fitting or Connector, remove the tube from the T-Fitting or Connector and rub dish soap into the inside ends of the tubing to remove any grease. Rinse with water before re-attaching.

**Caution:** Never expose the Companion, Reservoir, or accessories to heat from a dishwasher, microwave or boiling water. Only use lukewarm water from the faucet. Do not use any of the following liquids to clean the device: alcohol, ethanol, bleach, acetone (nail polish remover), hydrogen peroxide, or household/multi-purpose cleaners. Use of any of these liquids can damage the plastic components and labeling, and if not rinsed all the way, may result in those chemicals getting into your stomach the next time you use the device. Only use mild dish soap, baking soda or vinegar, mixed with water.

### 10.4 Skin-Port and Site Cleaning Instructions

After using the AspireAssist, use a paper towel to dry any fluid seen on the Skin-Port. During your daily bath or shower, use mild unscented soap and water to gently wash the Skin-Port and the skin underneath the Skin-Port. Avoid use of soaps or lotions containing essential oils, plant oils (such as Coconut), insect repellants containing DEET or Citronella oil. These oils may damage the Skin-Port and flange. Your skin should be patted dry afterwards with a towel. The area around the stoma should be kept as dry as possible at all times (except when bathing). Do not use creams or powders around the stoma site unless instructed by your doctor.

You may need to use gauze pads between the Skin-Port and the skin to keep the area dry. If you do use them, gauze pads should be placed flat and replaced as needed to keep the area dry.

### 10.5 A-Tube Cleaning Instructions

The A-Tube does not need any special cleaning procedures. Flushing the A-Tube happens during each use when you squeeze water from the Reservoir into your stomach.

## 11. LEARNING HOW TO ASPIRATE SUCCESSFULLY

About two weeks after your A-Tube placement procedure, you'll do your first aspiration in the doctor's office. First, you will eat a small meal, such as yogurt or applesauce. Then you will be shown how to use the AspireAssist, and talk about how you can make changes in the way you eat to make the aspiration process easier. Then, you will aspirate your first meal at the doctor's office, usually in a private restroom, before you go home. As you get more familiar with using the device, the process will get faster and easier.

### 11.1 Introducing Foods Little by Little

When you first begin to aspirate, you will need to learn to chew your food extremely carefully to get the food to fit through the tube. This is a habit that will take some effort to change, because you will have to eat your food much more slowly than before. You will also need to drink at least one bottle (500ml or 16ozs) of water with every meal, to help the flow of stomach contents through the tube.

To help you get started it might be easier to begin with foods that are easier to aspirate, and slowly add in foods that might be harder to chew well.

#### Stage 1: Pureed Foods

For the first week that you begin aspirating, start with foods that *do not need chewing*. This might be mashed or pureed foods that are smooth consistency. You can use a food processor or blender to get foods to be smooth. With these foods, meals should aspirate very easily. Use this week to learn how to use the device, clean it, and create a daily routine around aspiration.

Stage 1 Food Examples		
Fruits and Vegetables	Grains and Carbohydrates	Protein
Smoothies	Mashed potatoes (smooth)	Finely minced meats (i.e., with a food processor)
Smooth soups (not chunky)	Oatmeal	Cottage cheese
Pureed vegetables or fruits, such as applesauce	Rice	Yogurt

#### Stage 2: Soft and Ground Foods

**For the second week** of aspirating, you can begin eating foods that *need just a little chewing*. This includes very well cooked vegetables, or fruit that is chopped to the **size of a pencil eraser** or smaller. You can also eat ground meats and soft fish such as salmon or tilapia.

With these foods, meals should still aspirate very easily. If you find that aspirating is more difficult now and you start to get clogging, you will need to chew your food more carefully and choose foods that require less chewing. Make sure that everything you swallow is smaller than pencil eraser (this is about the same size as the tube). This means that it may take you more time to eat a meal, which is a great step towards healthy and mindful eating. Use this time to focus on chewing and making sure that you're drinking plenty of water during each meal to help flush the food out. Drinking plenty of water between meals is also helpful to keep you hydrated and avoid snacking.

Stage 2 Food Suggestions		
Fruits and Vegetables	Grains and Carbohydrates	Protein
Well-cooked or very finely chopped vegetables	Cereal	Ground Meats, including meatloaf or meatballs
Soft fruits such as banana, watermelon, pears, raspberries	Soft bread, cut into small pieces	Eggs (scrambled)
Finely chopped fruits	Well-cooked pasta	Soft fish (boiled, baked or broiled)
Canned fruits	Casseroles with ground meats and finely chopped vegetables	Tuna, Egg, or Chicken Salad (without celery)

Foods to avoid this week: Steak, chicken (except ground), shrimp, raw vegetables, leafy salads, fruits with tough skins or flesh (such as apple, oranges, or grapefruit), nuts, pizza.

**FAQ: I just started using the AspireAssist. How many calories should I be eating per day now?**

When you first begin using the device, there's a lot to learn! For the first few weeks, focus on learning to use the device and learning to chew carefully. Once you have mastered using the device while eating all your regular foods, your medical team will provide you with guidance on portion sizes, nutritional content, calories, physical activity, and more.

Stage 3: All Foods

Now it's time to add back in foods that require chewing. There are no specific foods that you need to eat at this stage, but be careful how small pieces are that you're swallowing. Your goal is for aspirating to still be as easy as during Stage 1 and 2. Keep in mind that just one big piece can cause clogging and slow the process down, and remember to keep drinking plenty of water. Refer to the section "Tips for a Successful Aspiration" for suggestions about handling and preventing clogging.

There may be some foods that you simply cannot aspirate easily, no matter how carefully you chew. If this happens, it might help to cut that food into very small pieces before you eat it next time, or wait a little longer to aspirate it. You may find that certain foods like meats or vegetables take longer to digest before you can easily aspirate them.

**11.2 Four Keys to Losing Weight with the AspireAssist**

Losing weight with the AspireAssist is different from other weight loss methods. You can make slow and steady changes to your lifestyle, and still lose weight successfully. But like any weight loss method, it takes commitment! It's not a magic bullet, but rather a tool for success. Here are the keys to getting the most out of your AspireAssist:

**1. Aspirate Regularly.** The most successful patients aspirate after each main meal, three times per day, even when life gets busy. Focus on aspirating after your three biggest (or highest calorie) meals of the day. Although this is typically breakfast, lunch, and dinner, you may have less traditional meals due to work or family schedules, etc. Take time to think about when you eat, so you can plan out the best times to aspirate.

**2. Chewing.** The most important part of aspirating successfully is chewing your food so that there are no pieces that are bigger than a pencil eraser. You may find it's easier to cut certain foods into small pieces before eating it, or choose ground or minced versions of meats instead of steak. You'll know you've chewed enough when the tube doesn't clog frequently and you can aspirate in 5-10 minutes. When you have chewed your food completely, you can remove about 30% of the meal.

**3. Minimize Snacking.** Initially, you may feel hungry sooner as your body adjusts to the fewer calories. Since snacks are not aspirated, it is important to eat fewer snacks. When you do, choose small healthy snacks such as fruit or lean meats. You should also avoid high-calorie beverages such as soda, sweet coffee drinks (e.g., whipped cream and caramel or chocolate) and alcohol. Make sure you are eating meals on a regular schedule, so that you sit down for a healthy, balanced meal when you begin to feel hungry again.

**4. Gradual Lifestyle Changes.** Once you've gotten used to the AspireAssist, slowly add healthier habits into your daily routine to help you continue losing weight and maintain your weight loss. You might find making only one change at a time helps you stick to these new habits.

### 11.3 Other Tips for a Successful Aspiration

It takes time to get used to the aspiration process, so don't get discouraged if the process is time consuming or difficult at first. Although we've already discussed chewing, the most important part of a successful aspiration, this section provides some additional tips on how to aspirate successfully. Everyone is different, so try each of these approaches and talk to other patients to discover what works for you.

- **Aspiration timing might be longer (or shorter) for some foods.** On average, patients aspirate about 20 to 30 minutes after each meal. This gives the stomach enough time to break down the food so that you can aspirate it easily, but most of the food is still in the stomach. Some foods like meats or vegetables might take longer to digest before you can easily aspirate them. People digest foods at different paces, so it will be different for everyone. Over time, you'll learn which foods need more or less time before you can aspirate them. Keep a food and aspiration journal to help you in this learning process.
- **Drink water with meals.** Drinking at least 16 ounces of water with your meals helps you flush the food out more easily during the aspiration process. You might find that drinking water right before aspirating, or even while aspirating, is helpful.
- **Give your stomach "mixing time".** After you squeeze water into your stomach with the reservoir, you may find it helpful to wait for 10 or 15 seconds to let the water mix with stomach contents. During this time, try squeezing your abdominal muscles, using your hands to gently press on your stomach (be careful

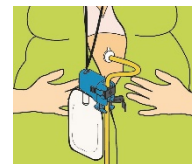

to not press on the Skin-Port or stoma site), or shifting your body around to help along the mixing process.

- **Squeeze the Connector Tube.** During the draining step, try squeezing the Connector tube (blue tube) with one hand then quickly releasing it. This can help the food drain more easily if there are very small blockages in the tube.

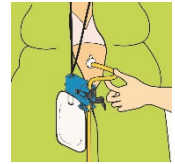

## 11.4 Troubleshooting

### Breakage or Failure

If any part of the device breaks or won't go together correctly, don't use the device and contact your doctor or nurse for a replacement. There is no harm if the device cannot be put together, however, you may miss several aspirations until it can be replaced.

### Clogging

If the A-Tube appears to be clogged, fill the Reservoir with lukewarm water (never hot water) and squeeze the water in short burst into the stomach to try and loosen the clog. Be careful to not use too much water at a time because it can make you feel very full and uncomfortable. If the A-Tube cannot be cleared, wait several hours, then try again. If the tube remains clogged after 24 hours, contact your doctor or nurse to have the A-Tube unclogged.

**Warning:** Do not use objects (e.g. wires, brushes, or other mechanical devices) to clean or unclog the A-Tube or Skin-Port. Using such objects might cause damage to your stomach such as injury to the stomach wall or you may put a hole in the stomach and cause an infection. Damage to the A-Tube may also occur such as a tear or hole which may result in leakage of gastric contents, irritation of the stoma site and possibly require replacement of the A-Tube.

### Decrease in Aspiration Flow

If you notice that there is less flow of stomach contents than what you are used to seeing or that it takes a lot longer to finish aspirating, contact your doctor or nurse to have your A-Tube checked. It may be a sign that the part of the A-Tube that stays in your stomach is out of position, or there may be a clog.

### Irritation

**Warning:** If you notice a change in irritation, redness, discharge, or pain around the skin underneath the Skin-Port at any time, contact your doctor right away. It could be a sign of infection or other issue with the A-Tube. If the cause of the condition is not resolved it could result in further damage to the tissue. Keep the area clean and dry to prevent skin irritation.

## 12. LIVING WITH THE ASPIREASSIST

### 12.1 What to Expect During Follow-up Medical Appointments

After you begin therapy with the AspireAssist, you will need to see your doctor regularly to make sure you are losing weight in a safe and healthy way. Your doctor will tell you how often you need to come in for a



check-up based on your individual health. It is extremely important to go to each scheduled medical appointment. It is important to bring your supplies to each visit, especially the Connector.

These visits may include blood tests to make sure that your electrolyte levels, such as potassium, and other blood levels are normal. Your medical team will also make sure that the stoma site is healthy, and that your device is working well for you. As you lose weight and your abdomen gets thinner, you will also need to have your A-Tube shortened. This will be done during your regular medical visits in the doctor's office, takes just a few minutes and is not painful. Lifestyle counseling sessions may also be included in these medical visits, and will include a discussion of any changes in your eating habits. Finally, your medical team will provide you with any replacement supplies that you need to continue therapy, such as a new Connector.

### **12.2 Lifestyle Counseling and Group Meetings**

Lifestyle counseling is an important part of therapy with the AspireAssist. Although you may begin losing weight quickly just by aspirating regularly, lifestyle counseling will help you to reach and maintain your goal weight. If you are able to make changes in your lifestyle, you may be able to reduce the number of times per day you need to aspirate. Lifestyle counseling will typically be provided by your medical team after you begin therapy with the AspireAssist. This may include individual sessions, or may be offered in a group setting.

Therapy sessions are typically scheduled monthly and each month a different topic will be discussed. The first session will be focused on use of the AspireAssist and resolving any problems you may be having getting comfortable with the process. There will be sessions that help you set reasonable goals for changing how and what you eat, how to make better choices when you eat out, beginning to add activities and exercise to get you moving, how to deal with triggers that make you want to eat when you are not hungry, problem solving tools such as stress management and negative thinking patterns. The sessions are interactive so that you can work with the therapist on specific issues and set goals for how to change them. Change happens over time where we replace old habits with new ones and the sessions help keep us on track.

Your medical team may also invite you to attend group meetings where patients using the AspireAssist can provide support to each other. This is a great way to learn more about living with the device and making healthy changes. If available, attending and actively engaging in these meetings is strongly recommended.

Talk to your medical team about all the support resources available to you. You can also visit our website to learn about online resources provided to help you connect with other patients at [www.aspirebariatrics.com](http://www.aspirebariatrics.com).

### **12.3 When Do I Need to Have the AspireAssist Removed?**

After you reach your goal weight, you might begin to ask when you should have the device removed. Many patients worry that they will not be able to maintain their weight loss without using the device at least occasionally. The good news is that if you are still benefiting from the AspireAssist and not having

problems with the therapy, then you may continue with the therapy as long as you like. Note that over time various components of the AspireAssist will require replacement as described in Section 13.

However, other patients decide that they would like the device removed after they reach their goal weight. In this case, we recommend that you take *at least* a 3-month “holiday” from using the device, before the tube is removed, and watch your weight carefully. If you are able to maintain your weight loss, you and your medical team may decide that you are ready to have your tube removed. Remember that if you have not made enough changes to your lifestyle, you may re-gain weight after you stop aspirating.

Of course, if you or your doctor decides that the device is not working for you, or you are having problems with the device or therapy, it can be removed at any time. The procedure is similar to the placement procedure, although additional endoscopic intervention may be necessary to close the fistula tract.

#### **12.4 Your Patient Identification Card**

Right after your procedure, you will be provided with an identification card to carry with you at all times. The card provides basic information about your implanted tube, and can be helpful in a medical emergency or with security personnel, such as airport security.

#### **12.5 Magnetic Resonance Imaging (MRI), Travel and Airport Security**

The AspireAssist A-Tube and Skin-Port are made of plastic and silicone, and do not have any metal components. Both components are MR Safe, meaning that it is safe for you to have Magnetic Resonance Imaging (MRI) testing done with the A-Tube and Skin-Port in place.

You may safely walk through airport security or other security scanners. The components will not cause the metal detectors to alarm, however the tube or Skin-Port may be seen in the full-body scanners. In case of a pat down, ask security personnel to avoid patting on the Skin-Port and instead show them your Patient Identification Card.

There are no travel restrictions related to the AspireAssist.

**Warning:** If you travel to an area where the water from the sink is not safe to drink, you will need to fill your reservoir with bottled water instead. If you use water that is unsafe to drink in your reservoir, you could become sick.

#### **12.6 Taking Medications**

**Warning:** Medications should be taken at least **2 hours** before aspirating. This is to prevent the medication from being aspirated. If your medication is aspirated you may not receive the full effect of the medication and the condition that it is treating may worsen, such as increased blood pressure because the complete dose of medication was not digested prior to aspiration.

You can also take some medications right after aspirating or at bedtime. If medication must be taken with food or with your main meals, you may be able to take it right after aspirating, since most of your meal is still in your stomach. Alternatively, you might need to take them with a small snack in between meals. You should work with your medical team to determine the best schedule for taking your medications.

**Warning:** As you lose weight, some of your prescription medications may need to be reduced or stopped entirely. Make sure you discuss this with each Doctor who has prescribed you a medication to make sure that you are taking the proper medications and dosages to treat the specific medical condition.

### **12.7 If You Get Pregnant or Are Planning to Get Pregnant**

**Warning:** The AspireAssist has not been studied to decide if it is safe for pregnant women or the baby. During pregnancy, your abdomen will expand and the Skin-Port could get too tight on your skin, causing serious problems such as the A-Tube bumper could be pulled into the stomach wall resulting in a buried bumper requiring an endoscopic or surgical procedure to remove the A-Tube. If you are planning to become pregnant, you will need to have your A-Tube removed before you attempt to become pregnant. If you become pregnant while your A-Tube is in place, tell your doctor right away. Your AspireAssist doctor and your obstetrician will develop a plan to remove your A-Tube that is as safe as possible for you and your baby.

## **13. ACCESSORIES REPLACEMENT**

The AspireAssist Companion and other parts are intended to be used and replaced regularly. The products may have reached the end of their useful life if they stop working well, or begin to smell bad or show stains, or have a build-up of foreign matter that cannot be removed using the recommended cleaning methods described in this Patient Guide.

### **13.1 Connector**

The Connector must be replaced after 115 cycles. The left counter digit will be displayed in red beginning with 19 cycles left, indicating that the Connector will need to be replaced soon. When the Counter reads “00”, you have completed 115 cycles and you need to get a new Connector from your doctor. If you keep trying to use the Connector, it will read “- 9” and lock up to prevent future use. To replace the Connector, detach the old Connector from the Connector Tube, and attach the new Connector to the tube. It is important to bring your Connector to all follow-up visits.



### **13.2 Tubing Set and Reservoir**

The Tubing Set, which includes a Connector Tube, Drain Tube, and T-Fitting, may be replaced as desired, due to a bad smell or stains that cannot be removed using the cleaning methods described in this guide. On average, the tubing sets need to be replaced about every 6 months, and the Reservoir needs to be replaced approximately every 3 months, however this will vary by the frequency of use and care given to each item. Remember to be gentle when putting water into your stomach from the Reservoir. Squeeze slow and steady and infuse about a quarter to a third of the bottle each time. Each new Drain Tube and Connector Tube should be cut to the right length by your doctor before use.

### **13.3 Companion**

The Companion is designed to last for 12 months. This may vary with frequency of use and care given to the Companion.

### 13.4 Skin Port

The Skin Port is designed to last for up to 6 months.

### 13.5 A-Tube

The A-Tube is manufactured from medical grade silicone and designed to withstand the acidity of the stomach as well as the temperature of the body. The majority of patients will have the same A-Tube for one year or more. However, the A-Tube should be replaced at about three years of use to ensure the integrity of the gastric portion of the tube and ease of removal.

**Warning:** It is very important to inspect the section of the A-Tube between the abdomen and the Skin Port. Look for any changes in color, black spots or swelling. This could result in a tear or hole which may result in leakage of gastric contents, irritation of the stoma site and possibly require replacement of the A-Tube

The A-Tube may start to break down as a result of microorganisms which normally live in your stomach that can stick to each other and stick onto the inside of the section of A-Tube at the Skin Port causing the changes described in the warning above. The A-Tube would then need to be replaced through an endoscopic procedure similar to the original placement. However, since the replacement tube is placed in the same stoma site, there is very little if any discomfort in this area.

## 14. LIMITED WARRANTY









### 14.1 Limited Warranty

The AspireAssist and its components are warranted against manufacturing defects only. Since these products are intended to be used and replaced regularly, this warranty does not cover damage attributable to or resulting from normal wear (including odors, discoloration, and build-up of foreign matter) or abuse of the products. This warranty also does not cover alteration of the product or use of the product contrary to the Patient Guide.

For patients in the United States, warranty claims must be made through Aspire Bariatrics directly. For patients outside the United States, warranty claims must be made through the authorized AspireAssist distributor in your country. This warranty is limited to the replacement of the defective part. Aspire Bariatrics shall in no event be responsible for any incidental or consequential damages other than as expressly provided by specific law.

This limited warranty is the only express or implied warranty applicable to the Aspire products. Any implied warranties, including warranties of merchantability and fitness for a particular purpose shall be limited in scope and duration in accordance with this limited warranty.

## 15. SYMBOLS

	Catalog number		Batch code
	Manufacturer		Use by date
	Consult instructions for use		Authorized representative in the European community
	Single Patient Use		Non-Sterile

## 16. CONTACT

Doctor name: \_\_\_\_\_

Doctor number: \_\_\_\_\_

### **Aspire Bariatrics, Inc.**

Technical support: 1-877-312-0007

319 N Pottstown Pike, Suite 202

Exton, PA 19341 USA

+1 (610) 590-1577

[www.aspirebariatrics.com](http://www.aspirebariatrics.com)

[info@aspirebariatrics.com](mailto:info@aspirebariatrics.com)